



JCB GROUNDCARE | ZT20D ZERO TURN



ENGINE POWER

13.3kW (17.8hp) DIESEL

MAX. TRAVEL SPEED

14.5km/h (9mph)

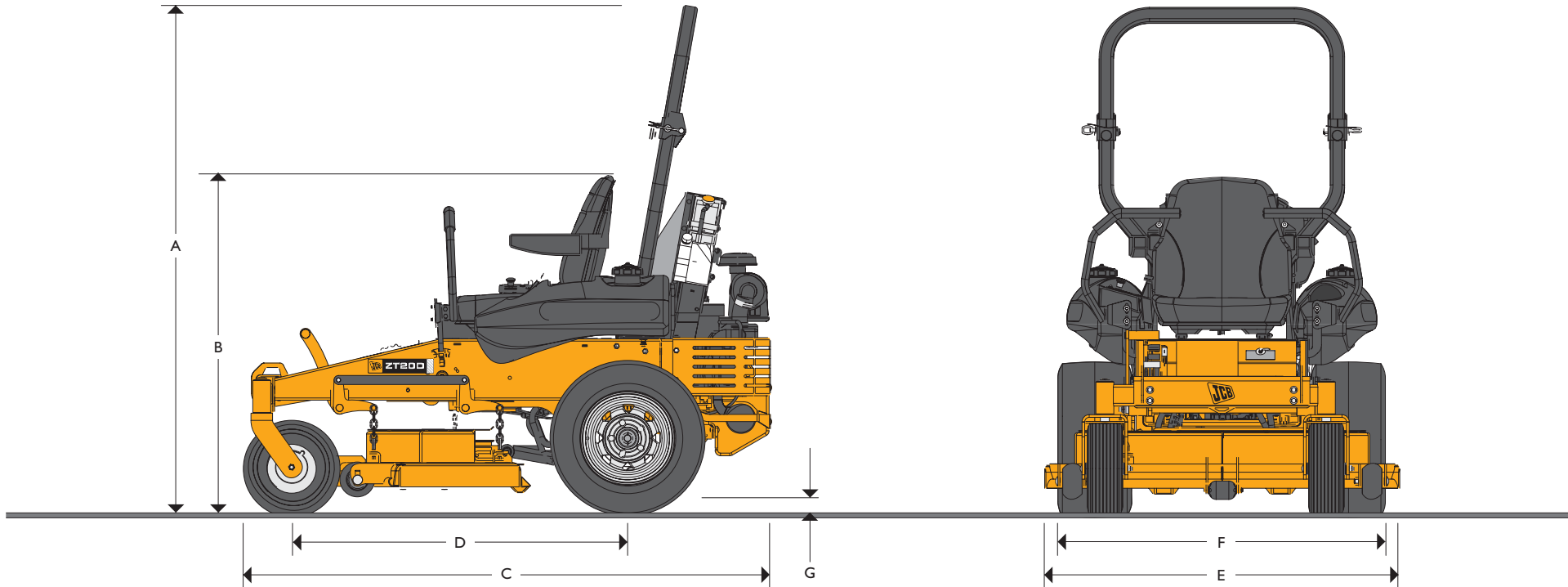

STATIC DIMENSIONS

Machine model	ZT20D
	mm (in)
A Overall height with ROPS	1803 (71)
B Overall height without ROPS	1232 (48.5)
C Overall length	1930 (76)
D Wheelbase	1186 (46.7)
E Overall width – 48 inch deck	1255 (49.4)
E Overall width – 52 inch deck	1370 (54.0)

Machine model	ZT20D
	mm (in)
F Overall width without deck	1161 (45.7)
G Ground clearance*	127 (5)
Shipping weight with 48" RD Mower Deck and ROPS	kg (lb) 546 (1203)
Shipping weight with 52" SD Mower Deck and ROPS	kg (lb) 588 (1296)

*With deck in the transport position.



JCB GROUND CARE | ZT20D ZERO TURN



ENGINE

Model	ZT20D	
Engine	Yanmar 2V750-CVER	
Type	V-Twin Liquid Cooled	
Displacement	cc (cu. in.)	749 (45.7)
Power @ 3200 rpm	kW (hp)	13.3 (17.8)
Maximum torque	Nm (lb-ft)	46 (33.9)
Bore	mm (in)	78 (3.07)
Stroke	mm (in)	78.4 (3.09)
Crankcase capacity	litres (gal)	2.27 (0.5)

FUEL

Type	Diesel	
Tank capacity – both tanks	litres (gal)	44.8 (9.9)

HYDROSTATIC DRIVE SYSTEM

Steering	2 hand levers	
Transmission	Twin pumps and wheel motors	
Hydraulic system capacity	litres (gal)	3.8 (0.84)
Maximum travel speed – Forward	km/h (mph)	14.5 (9)
Maximum travel speed – Reverse	km/h (mph)	4.83 (3)
Tyre Size		
Rear	Drive tyres, 23x10.5 – I2 turf tread	
Front	Caster tyres, 13 x 5.00 – 5 ribbed tread	

ROLL OVER PROTECTIVE STRUCTURE

Folding ROPS.

PARKING BRAKE

Motion control lever actuated. Integrated steering lever disc brakes.

ELECTRICAL SYSTEM

Battery	12V 433 CCA – negative earth	
Charging system	20 amp	
Starter	12V Electric	
Fuse protection	30 amp	
Power Take Off (PTO)	Ogura® GT-2.5 clutch	
Blade brake	Dry single disk (thru PTO clutch/brake)	

MOWER DECK

Style	Rear discharge deck	Side discharge deck
Dimensions		
Cutting width	mm (in)	1220 (48)
Cutting height adjustment	mm	38 – 140 mm in 6 mm increments
Cutting height adjustment	in	1.5 – 5.5 in in 0.25 in increments
Width overall	mm (in)	1255 (49.4)
Depth	mm (in)	80 (3.1)
Steel thickness	Full 7 gauge – welded construction	Full 7 gauge – welded construction
Deck lift	Foot operated	Foot operated
Cut height adjustment	Fingertip control dial gauge	Fingertip control dial gauge
Mowing Blades		
Tip speed	m/min (fpm)	4999 (16,400)
Length	mm (in)	419 (16.50)
Thickness	mm (in)	4.98 (0.196)
Number of blades	3	3
Anti-scalp rollers	3	6

* Excludes discharge shield

OPTIONS

Collector for side discharge deck. 436L (0.57 cu. yds) capacity with three bags for ease of handling. Belt/gearbox driven fan with 3025rpm fan speed.



Printed in the UK on paper made from sustainable forests. The pulp used in the manufacture of this paper is made from renewable timber produced on a fully sustainable basis, and is bleached without the use of chlorine gas (ECF – Elemental Chlorine Free). This paper is suitable for recycling.

JCB Groundcare, Rocester, Staffordshire ST14 5JP. Tel: 01889 590312. Fax: 01889 590348. www.jcb.co.uk

JCB reserves the right to change specifications without notice. Illustrations shown may include optional equipment and accessories. The JCB logo is a registered trademark of J C Bamford Excavators Ltd.



9999/5232 2/07 Issue 2

A Product of Hard Work